



Standard Test Method for Mechanical Cone Penetration Tests of Soil¹

This standard is issued under the fixed designation D 3441; the number immediately following the designation indicates the year of original adoption or, in the case of revision, the year of last revision. A number in parentheses indicates the year of last reapproval. A superscript epsilon (ϵ) indicates an editorial change since the last revision or reapproval.

This standard has been approved for use by agencies of the Department of Defense.

1. Scope

1.1 This test method covers the determination of end bearing and side friction, the components of penetration resistance that are developed during the steady slow penetration of a pointed rod into soil. This test method is sometimes referred to as the Dutch Cone Test or Cone Penetration Test and is often abbreviated as CPT.

1.2 This test method includes the use of mechanical cone and friction-cone penetrometers. It does not include the use of electric and electronic cones or data interpretation.

1.2.1 The use of electric and electronic cones is covered in Test Method D 5578.

1.3 Mechanical penetrometers of the type described in this test method operate incrementally, using a telescoping penetrometer tip, resulting in no movement of the push rods during the measurement of the resistance components. Design constraints for mechanical penetrometers preclude a complete separation of the end-bearing and side-friction components.

1.4 The values stated in inch-pound units are to be regarded as the standard. The values given in parentheses are provided for information only.

1.5 *This standard does not purport to address all of the safety concerns, if any, associated with its use. It is the responsibility of the user of this standard to establish appropriate safety and health practices and determine the applicability of regulatory limitations prior to use.*

2. Referenced Documents

2.1 ASTM Standards:

D 653 Terminology Relating to Soil, Rock, and Contained Fluids

D 5778 Test Method for Performing Electronic Friction Cone and Piezocone Penetration Testing of Soil

2.2 Other Standards:

USBR D 7020 Performing Cone Penetration Testing of Soils—Mechanical Method *Earth Manual*, Part II, Third Edition, U.S. Department of the Interior, Bureau of Reclamation, U.S. Government Printing Office, 1990

“International Reference Test Procedure for the Cone

Penetration Test (CPT),” Proceedings of the First International Symposium for Penetration Testing, ISOPT-1 DeRuiter, ed., Blakema, Rotterdam, ISBN 90 6191 8014, 1988.

3. Terminology

3.1 Definitions:

3.1.1 *cone, n*—the cone-shaped point of the penetrometer tip, upon which the end-bearing resistance develops.

3.1.2 *cone penetrometer, n*—an instrument in the form of a cylindrical rod with a conical point designed for penetrating soil and soft rock and for measuring the end-bearing component of penetration resistance.

3.1.3 *cone resistance, or end-bearing resistance q_c, n* —the resistance to penetration developed by the cone equal to the vertical force applied to the cone divided by its horizontally projected area.

3.1.4 *cone sounding, n*—the entire series of penetration tests performed at one location when using a cone penetrometer.

3.1.5 *friction-cone penetrometer, n*—a cone penetrometer with the additional capability of measuring the local side friction component of penetration resistance.

3.1.6 *friction cone sounding, n*—the entire series of penetration tests performed at one location when using a friction cone penetrometer.

3.1.7 *friction ratio, R_f, n* —the ratio of friction resistance to cone resistance, f_s/q_c , expressed in percent.

NOTE 1—The friction ratio for mechanical penetrometers is not comparable to the friction ratio measured by electronic or electrical penetrometer (Test Method D 5778). Users should verify that the application of empirical correlations such as those predicting soil type from R_f are for the correct penetrometer.

3.1.8 *friction resistance, f_s, n* —the resistance to penetration developed by the friction sleeve, equal to the vertical force applied to the sleeve divided by its surface area. This resistance consists of the sum of friction and adhesion.

3.1.9 *friction sleeve, n*—a section of the penetrometer tip upon which the local side-friction resistance develops.

3.1.10 *inner rods, n*—rods that slide inside the push rods to extend the tip of a mechanical penetrometer.

3.1.11 *mechanical penetrometer, n*—a penetrometer that uses a set of inner rods to operate a telescoping penetrometer tip and to transmit the component(s) of penetration resistance to the surface for measurement.

¹ This test method is under the jurisdiction of Committee D-18 on Soil and Rock and is the direct responsibility of Subcommittee D18.02 on Sampling and Related Field Testing for Soil Investigations.

Current edition approved May 10, 1998. Published January 1999. Originally published as D 3441 – 75 T. Last previous edition D 3441 – 94.

3.1.12 *penetrometer tip, n*—the end section of the penetrometer, which comprises the active elements that sense the soil resistance, the cone, and in the case of the friction-cone penetrometer, the friction sleeve.

3.1.13 *push rods, n*—the thick-walled tubes, or other suitable rods, used for advancing the penetrometer tip to the required test depth.

4. Significance and Use

4.1 This test method supplies data on selected engineering properties of soil intended to help with design and construction of earthworks and the foundations for structures.

4.2 This test method tests the soil in place and does not obtain soil samples. The interpretation of the results from this test method requires knowledge of the types of soil penetrated. Engineers usually obtain this soil information from parallel borings and soil sampling methods, but prior information or experience may preclude the need for borings.

4.3 Engineers often correlate the results of tests by this test method with laboratory or other types of field tests or directly with performance. The accuracy of such correlations will vary with the type of soil involved. Engineers usually rely on local experience to judge this accuracy.

5. Apparatus

5.1 *General:*

5.1.1 *Cone*—The cone shall have 60°(±5°) point angle and a base diameter of 1.406± 0.016 in. (35.7 ± 0.4 mm), resulting in a projected area of 1.55 in.² (10 cm²). The point of the cone shall have a radius less than 1/8 in. (3 mm).

5.1.2 *Friction Sleeve*—having the same outside diameter +0.024 to -0.000 in. (+0.5 to -0.0 mm) as the base diameter of the cone (see 5.1.1). No other part of the penetrometer tip shall project outside the sleeve diameter. The surface area of the sleeve shall be 23.2 in.² (150 cm²) ± 2 %.

5.1.3 *Steel*—The cone and friction sleeve shall be made from steel of a type and hardness suitable to resist wear due to abrasion by soil. The friction sleeve shall have and maintain with use a roughness of 63 μin. (1.6 μm) AA, ±50 %.

5.1.4 *Push Rods*—Made of suitable steel, these rods must have a section adequate to sustain without buckling, the thrust required to advance the penetrometer tip. They must have an outside diameter not greater than the diameter of the base of the cone for a length of at least 1.3 ft (0.4m) above the base, or, in the case of the friction-cone penetrometer, at least 1.0 ft (0.3 m) above the top of the friction sleeve. Each push rod must have the same constant inside diameter. They must screw or attach together to bear against each other and form a rigid-jointed string of rods with a continuous, straight axis.

5.1.5 *Inner Rods*—Mechanical penetrometers require a separate set of steel or other metal alloy inner rods within the steel push rods. The inner rods must have a constant outside diameter with a roughness less than 125 μin. (3.2 μm) AA. They must have the same length as the push rods (± 0.004 in. or ± 0.1 mm) and a cross section adequate to transmit the cone resistance without buckling or other damage. Clearance between inner rods and push rods shall be between 0.020 and 0.040 in. (0.5 and 1.0 mm) (see 7.8.1).

5.1.6 *Measurement Accuracy*—Maintain the trust-

measuring instrumentation to obtain trust measurements within ±5 % of the correct values. Measurement equipment (see 5.2.5) should be subjected to calibration at regularly scheduled intervals such as annually or after a specified amount of accumulated testing. Examples of mechanical cone testing calibration can be found in USBR D 7020 and ISOPT-1.

NOTE 2—Special, and preferably redundant, instrumentation may be required in the offshore environment to ensure this accuracy and the proper operation of all the remote systems involved.

5.2 *Mechanical Penetrometers:*

5.2.1 The sliding mechanism necessary in a mechanical penetrometer tip must allow a downward movement of the cone in relation to the push rods of at least 1.2 in. (30.5 mm).

NOTE 3—At certain combinations of depth and tip resistance(s), the elastic compression of the inner rods may exceed the downward stroke that the trust machine can apply to the inner rods relative to the push rods. In this case, the tip will not extend and the trust readings will rise elastically to the end of the machine stroke and then jump abruptly when the trust machine makes contact with the push rods.

5.2.2 Mechanical penetrometer tip design shall include protection against soil entering the sliding mechanism and affecting the resistance component(s) (see 5.2.3 and Note 3).

5.2.3 *Cone Penetrometer*—Fig. 1 shows the design and action of one mechanical cone penetrometer tip. A mantle of reduced diameter is attached above the cone to minimize possible soil contamination of the sliding mechanism.

NOTE 4—An unknown amount of side friction may develop along this mantle and be included in the cone resistance.

5.2.4 *Friction Cone Penetrometer*—Fig. 2 shows the design and action of one telescoping mechanical friction cone penetrometer tip. The lower part of the tip, including a mantle to which the cone attaches, advances first until the flange engages the friction sleeve and then both advance.

NOTE 5—The shoulder at the lower end of the friction sleeve encounters end-bearing resistance. In sand, as much as two thirds of the sleeve resistance may consist of bearing on this shoulder. Ignore this effect in soft to medium clays.

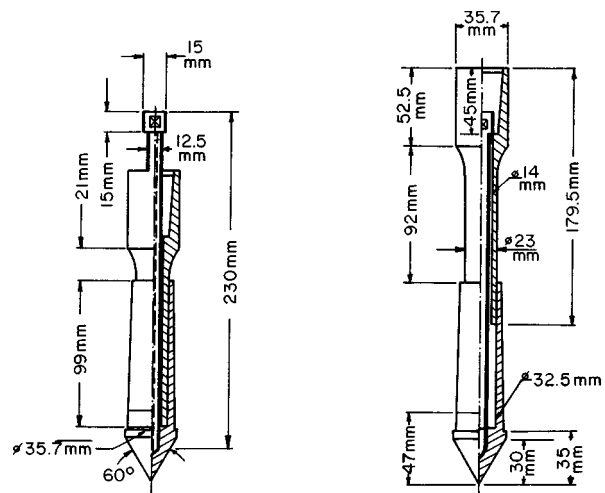

COLLAPSED EXTENDED
FIG. 1 Example of a Mechanical Cone Penetrometer Tip (Dutch Mantle Cone)

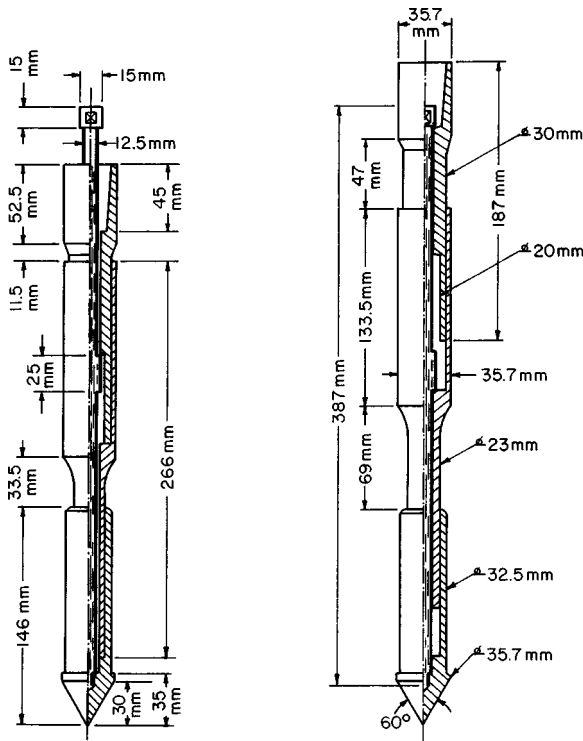

FIG. 2 Example of a Mechanical Friction-Cone Penetrometer Tip (Begemann Friction-Cone)

5.2.5 *Measuring Equipment*—Measure the penetration resistance(s) at the surface by a suitable device such as a hydraulic or electric load cell or proving ring.

5.3 *Thrust Machine*—This machine shall provide a continuous stroke, preferably over a distance greater than one push rod length. The machine must advance the penetrometer tip at a constant rate while the magnitude of the thrust required fluctuates (see 6.1.2).

NOTE 6—Deep penetration soundings usually require a thrust capacity of at least 5 tons (45kN). Most modern machines use hydraulic pistons with 10 to 20-ton (90 to 180-kN) thrust capability.

5.4 *Reaction Equipment*—The proper performance of the static-thrust machine requires a stable, static reaction.

NOTE 7—The type of reaction provided may affect the penetrometer resistance(s) measured, particularly in the surface or near-surface layers.

6. Procedure

6.1 *General:*

6.1.1 Set up the thrust machine for a thrust direction as near vertical as practical.

6.1.2 *Rate of Penetration*—Maintain a rate of depth penetration of 2 to 4 ft/min (10 to 20 mm/s) ± 25 %.

NOTE 8—The rate 2 ft/min (10 mm/s) provides the time the operator needs to properly read the resistance values when using the mechanical friction-cone penetrometer. The rate of 4 ft/min (20 m/s) is suitable for the single resistance reading required when using the mechanical cone penetrometers. The European standard requires 4 ft/min (20 mm/s).

6.2 *Mechanical Penetrometers:*

6.2.1 *Cone Penetrometers*—(1) Advance penetrometer tip to the required test depth by applying sufficient thrust on the push rods, and (2) Apply sufficient thrust on the inner rods to extend the penetrometer tip (see Fig. 1). Obtain the cone resistance at a specific point (see 6.2.3) during the downward movement of the inner rods relative to the stationary push rods. Repeat step (1). Apply sufficient thrust on the push rods to collapse the extended tip and advance it to a new test depth. By continually repeating this two-step cycle, obtain cone resistance data at increments of depth. This increment shall not ordinarily exceed 8 in. (203 mm).

6.2.2 *Friction-Cone Penetrometer*—Use the procedure as described in 6.2.1, but obtain two resistances during step (2) extension of the tip (see Fig. 2). First obtain the cone resistance during the initial phase of the extension. When the lower part of the tip engages and pulls down the friction sleeve, obtain a second measurement of the total resistance of the cone plus the sleeve. Subtraction gives the sleeve resistance.

NOTE 9—Because of soil layering, the cone resistance may change during the additional downward movement of the tip required to obtain the friction measurement.

NOTE 10—The soil friction along the sleeve puts an additional overburden load on the soil above the cone and may increase cone resistance above that measured during the initial phase of the tip extension by an unknown but probably small amount. Ignore this effect.

6.2.3 *Recording Data*—To obtain reproducible cone-resistance test data, or cone and friction-resistance test data, when using a friction-cone tip, record only those thrust readings that occur at a well-defined point during the downward movement of the top of the inner rods in relation to the top of the push rods. Because of the elastic compression of inner rods (see Note 2), this point ordinarily should be at not less than 1.0 in. (25 mm) apparent relative movement of the inner rods. When using the friction-cone penetrometer, this point shall be just before the cone engages the friction sleeve.

NOTE 11—Fig. 3 shows one example of how the thrust in the hydraulic load cell can vary during the extension of the friction-cone tip. Note the jump in gage pressure when the cone engages the sleeve.

6.2.3.1 Obtain the cone plus friction-resistance reading as soon as possible after the jump so as to minimize the error described in Fig. 3. Unless using continuous recording as in Fig. 3, the operator should not record a cone plus friction resistance if he suspects the cone resistance is changing abruptly or erratically.

7. Special Techniques and Precautions

7.1 *Reduction of Friction Along Push Rods*—The purpose of this friction reduction is to increase the penetrometer depth capability, and not to reduce any differences between resistance components determined by mechanical tips as noted in 1.3. To accomplish the friction reduction, introduce a special rod with an enlarged diameter or special projections, called a “friction reducer,” into the string of push rods or between the push rods and the tip. Another allowable method to reduce friction is to use push rods with diameter less than that of the tip. Any such projections or changes in diameter must meet the restrictions of 5.1.4.

NOTE 12—Non-mechanical techniques to reduce friction, such as the

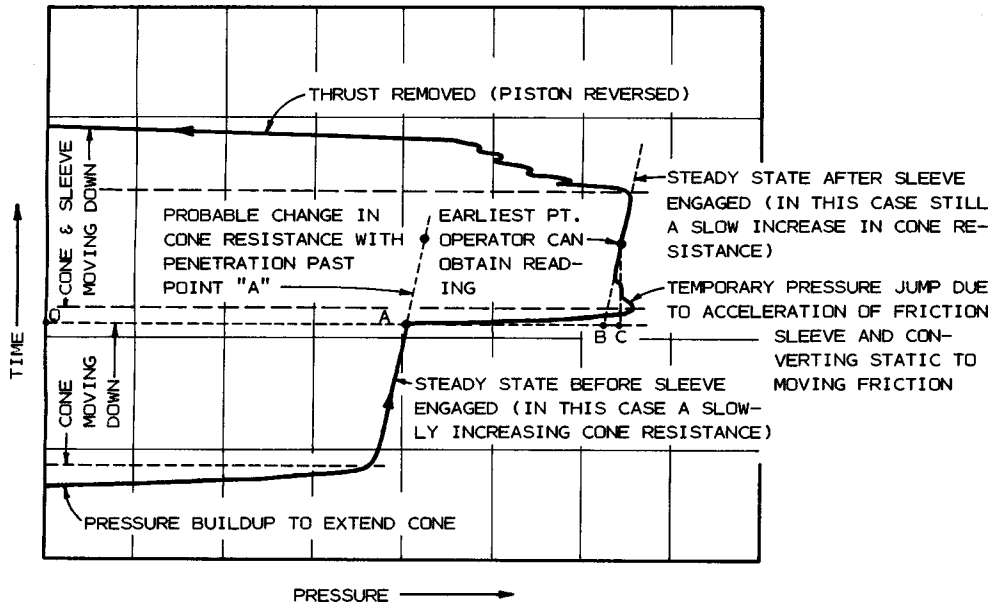

NOTE 1—"O-A" represents the correct cone resistance reading just before the pressure jump associated with engaging the friction sleeve during the continuing downward extension of the tip. "A-B" is the correct friction resistance if the friction sleeve could be engaged instantaneously and the cone plus friction resistance read instantaneously. However, the operator cannot read a pressure gage dial until it steadies, such as at Point "C." By this forced wait, the operator has introduced a friction resistance error of "B-C." The operator must read the gage as soon as possible after the jump to minimize this error. Erratic or abrupt changes in cone resistance may make this error unacceptable.

FIG. 3 Annotated Chart Record of the Pressure Changes in the Hydraulic Load Cell Measuring Thrust on Top of the Inner Rods During an Example Extension of the Mechanical Friction-Cone Penetrometer Tip

use of drilling mud above the tip, are also allowable.

7.2 Prevention of Rod Bending Above Surface—Use a tubular rod guide, at the base of the thrust machine, of sufficient length to prevent significant bending of the push rods between the machine and the ground surface.

NOTE 13—Special situations, such as when working through water, will require a special system of casing support to adequately restrict the buckling of the push rods.

7.3 Drift of Tip—For penetration depth exceeding about 40 ft (12 m), the tip will probably drift away from a vertical alignment. Occasionally, serious drifting occurs, even at less depth. Reduce drifting by using push rods that are initially straight and by making sure that the initial cone penetration into soil does not involve unwanted initial lateral thrust. Passing through or alongside an obstruction such as boulders, soil concentrations, thin rock layers, or inclined dense layers, may deflect the tip and induce drifting. Note any indications of encountering such obstructions and be alert for possible subsequent improper tip operation as a sign of serious drifting.

7.4 Wear of Tip—Penetration into abrasive soils eventually wears down or scours the penetrometer tip. Discard tips, or parts thereof, whose wear changes their geometry or surface roughness. Permit minor scratches.

7.5 Distance Between Cone and Friction Sleeve—The friction resistance of the sleeve applies to the soil at some distance above the soil in which the cone resistance was obtained at the same time. When comparing these resistances for the soil at a specified depth, for example when computing friction ratios or when plotting these data on graphs, take proper account of the vertical distance between the base of the cone and the mid-height of the friction sleeve.

7.6 Interruptions—The engineer may have to interrupt the normal advance of a static penetration test for purposes such as removing the penetrometer and drilling through layers or obstructions too strong to penetrate statically. If the penetrometer is designed to be driven dynamically without damage to its subsequent static performance (those illustrated in Figs. 1 and 2 are not so designed), the engineer may drive past such layers or obstructions. Delays of over 10 min due to personnel or equipment problems shall be considered an interruption. Continuing the static penetration test after an interruption is permitted, provided this additional testing remains in conformance with this test method. Obtain further resistance component data only after the tip passes through the engineer's estimate of the disturbed zone resulting from the nature and depth of the interruption. As an alternative, readings may be continued without first making the additional tip penetration and the disturbed zone evaluated from these data. Then disregard data within the disturbed zone.

7.7 Below or Adjacent Borings—A cone or friction-cone sounding shall not be performed any closer than 25 boring diameters from an existing, unbackfilled, uncased boring hole. When a sounding is performed at the bottom of a boring, the engineer should estimate the depth below the boring of the disturbed zone and disregard penetration test data in this zone. The depth may vary from one to five diameters. Where the engineer does not have sufficient experience with this variable, depth of at least three boring diameters should be used.

7.8 Mechanical Penetrometers:

7.8.1 Inner Rod Friction—Soil particles and corrosion can increase the friction between inner rods and push rods, possibly resulting in significant errors in the measurement of the

resistance component(s). Clean and lubricate the inner rods.

7.8.2 *Weight of Inner Rods*—For improved accuracy at low values of cone resistance, correct the thrust data to include the accumulated weight of the inner rods from the tip to the topmost rod.

7.8.3 *Jamming*—Soil particles between sliding surfaces or bending of the tip may jam the mechanism during the many extensions and collapses of the telescoping mechanical tip. Stop the sounding as soon as uncorrectable jamming occurs.

8. Report

8.1 *Graph of Cone Resistance, q_c* —Every report of a cone or friction-cone sounding shall include a graph of the variation of cone resistance (in units of tons or kPa) with depth (in feet or meters). Successive cone-resistance test values from the mechanical cone and friction-cone penetrometers, usually determined at equal increments of depth and plotted at the depth corresponding to the depth of the measurement, may be connected with straight lines as an approximation for a continuous graph.

8.2 *Friction-Cone Penetrometer:*

8.2.1 *Graph of Friction Resistance, f_s* —In addition to the graph of cone resistance (8.1), the report may include an adjacent or superimposed graph of friction resistance or friction ratio, or both, with depth. Use the same depth scale as in 8.1 (see 7.5).

8.2.2 *Graph of Friction Ratio, R_f* —If the report includes soil descriptions estimated from the friction-cone penetrometer data, include a graph of the variation of friction ratio with depth. Place this graph adjacent to the graph for cone resis-

tance, using the same depth scale (see 7.5).

8.3 *General*—The operator shall record his name, the name and location of the job, date of sounding, sounding number, location coordinates, and soil and water surface elevations (if available). The report also shall include a note as to the type of penetrometer tip used, the type of thrust machine, tip and thrust calibration information, or both, any zero-drift noted, the method used to provide the reaction force, if a friction reducer used to provide the reaction force, if a friction reducer was used, the method of tip advancement, the method of recording, the condition of the rods and tip after withdrawal, and any special difficulties or other observations concerning the performance of the equipment.

8.4 *Deviations From Standard*—The report shall state that the test procedures were in accordance with this test method. Describe completely any deviations from this test method.

9. Precision and Bias

9.1 *Precision*—It is not practical to specify the precision of the procedure in this test method for measuring cone end bearing and side friction in soils because it is a field test method used in nonuniform materials.

9.2 *Bias*—No information can be presented on the bias of the procedure in this test method because there is no material having an accepted reference value available.

10. Keywords

10.1 cone; CPT; Dutch Cone; friction; *In-situ test*; penetration test

The American Society for Testing and Materials takes no position respecting the validity of any patent rights asserted in connection with any item mentioned in this standard. Users of this standard are expressly advised that determination of the validity of any such patent rights, and the risk of infringement of such rights, are entirely their own responsibility.

This standard is subject to revision at any time by the responsible technical committee and must be reviewed every five years and if not revised, either reapproved or withdrawn. Your comments are invited either for revision of this standard or for additional standards and should be addressed to ASTM Headquarters. Your comments will receive careful consideration at a meeting of the responsible technical committee, which you may attend. If you feel that your comments have not received a fair hearing you should make your views known to the ASTM Committee on Standards, 100 Barr Harbor Drive, West Conshohocken, PA 19428.